

User's Manual

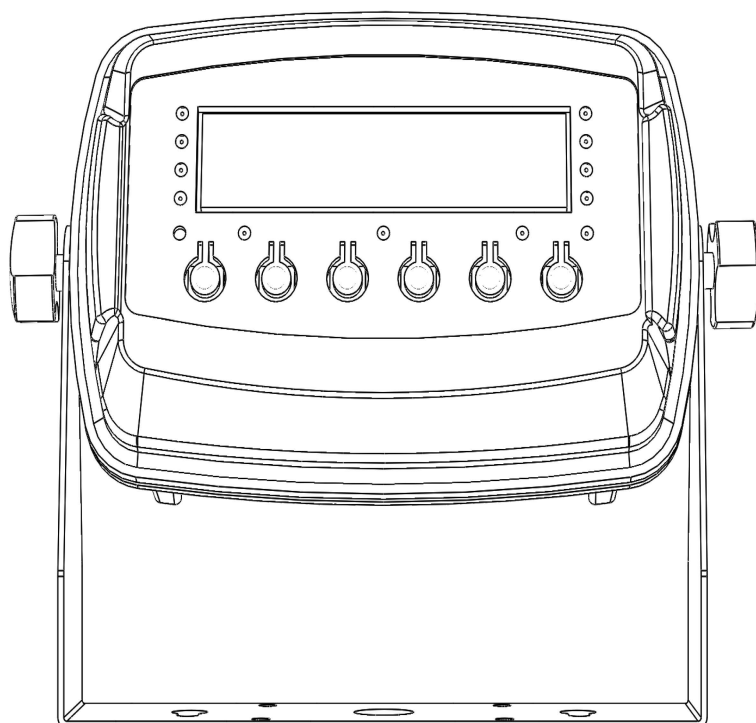

TABLE OF CONTENTS

SAFETY PRECAUTIONS	1
PREPARATION & SET UP	1
FEATURES	2
SPECIFICATIONS	3
POWER SUPPLY	3
DISPLAY AND KEY DESCRIPTION	4
OPERATING INSTRUCTIONS	6
CALIBRATION PROCEDURE	7
INDICATOR PARAMETER SETTINGS	9
CONNECTORS	14
TROUBLESHOOTING	19

SAFETY PRECAUTIONS

Please read and follow all the instructions before using the unit. Calibration, inspections, and maintenance shall be performed by professionals

- Make sure the indicator is on a stable surface.
- DO NOT disassemble or modify unit.
- DO NOT exceed the rated load limit of the unit.
- DO NOT use this product if there are any signs of damage.
- DO NOT use for purposes other than weighing.
- Keep other electronic equipment away from the unit.

Electrical Safety

- Unit must be connected to a GFCI outlet.
- Disconnect power before servicing unit.
- All operators MUST discharge themselves before servicing unit.
- Always pull the plug – not the cord – when disconnecting from the outlet.
- DO NOT use if the power cord is worn or damaged
- Power cord should only be replaced by certified service technicians using the original parts

PREPARATION & SET UP

- If the indicator is powered with an adapter, plug the adapter directly into the “DC” pin located at the bottom of the indicator.
- Always use a wall outlet to avoid interference from other wires
- Turn on the indicator when there is no load
- Calibrate before weighing when the scale is initially installed or moved to a new location

FEATURES

Main Features

- LED display
- Weighing units
lb/kg or lb/kg/g/oz/lb-oz (only on upgraded model)
- Gross/Tare/Pre-Set Tare/Zero
- Multiple Hold functions
- Overload / Underload indication
- Configurable with multiple printers
- Splash proof keyboard and display
- Connects to a Remote Display/Scoreboard
- Power saving mode
- Ability to modify gravity based on different geographical locations
- RS232 output
- Optional dual load cell ports

Technical Parameters

Accuracy class	5000 e
Zero stability error	$TK0 < 0.1 \mu V // K$
Span stability error	$TK_{spn} < \pm 6 \text{ ppm} // K$
Sensitivity (internal)	$0.3 \mu V / d$
Input voltage	-30 to +30mV DC
Excitation circuit	5 VDC, 4 or 6 wire connection, 8 load cells of 350ohm max
AC power	AC 100-250V (use only the included 9V adapter supplied)
Operation temperature	14-104°F (-10 °C ~ +40 °C)
Operation humidity	$\leq 90\%RH$
Storage temperature	-40-158°F (-40 °C ~ +70 °C)

SPECIFICATIONS

INDICATOR MEASUREMENTS

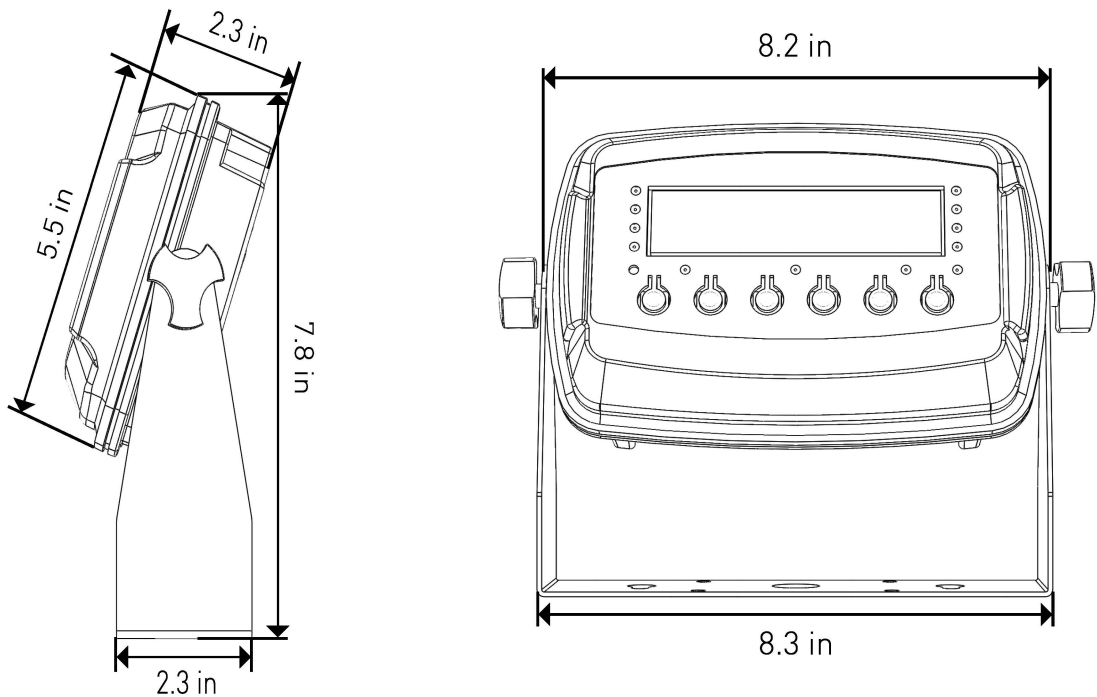

POWER SUPPLY

AC Adapter

If the indicator is powered with an adapter, plug the adapter directly into the “DC” pin located at the bottom of the indicator. It is recommended to plug into a wall outlet to avoid interference with wirings.

Battery

If you have an indicator with the rechargeable battery option, please charge the internal battery fully before first time use. A 110 to 220V AC adapter should be provided with your indicator. Please use only the AC adapter provided. To keep the battery in the best condition, fully discharge the battery every month by leaving the indicator on until the indicator powers off, and then recharge fully. If the battery will not be used for long time, please remove it to avoid leakage.

LIGHT INDICATION AND KEYPAD

FRONT VIEW

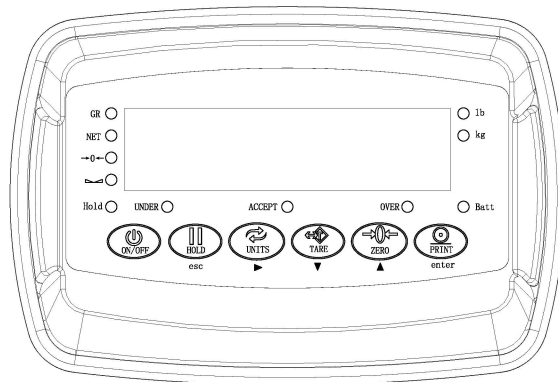

1. LIGHT INDICATION

lb: ON when the weight unit is pound [lb]

kg: ON when the weight unit is kilogram [kg]

g: ON when the weight unit is gram [g]

oz: ON when the weight unit is oz [oz]

Batt: GREEN when the battery is fully charged; RED when it is low

GROSS: ON when the current weight is the GROSS weight

NET: ON when the current weight is the NET weight

ZERO: ON when the current weight is 0 lb (0 kg)

HOLD: ON when the weight value is being held

UNDER: ON when the weight is below the min preset value

ACCEPT: ON when the weight is within the acceptable range

OVER: ON when the weight is over the max preset value

2. KEYPAD



Power on or off (Press hard and hold for 2 seconds)



Weight value hold (5 Hold options; can be changed in parameter settings)



Shift between weighing units



1. Resets the scale to zero when there is something on the scale (ex. Tare out the weight of a pallet to weigh only the items on it)
2. Clears tare weight for gross weight



Zero's the scale



Prints



Save and Exit



Arrow keys



Enter

BOTTOM VIEW

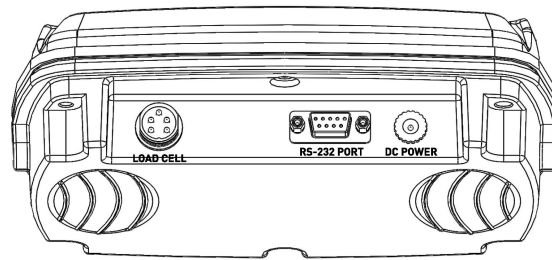

- LOAD CELL: Port for connecting the scale.
- RS-232 PORT: Serial interface port. (printer, second display, PC, etc.)
- DC POWER: Port for DC power. (DC 9V adapter available)

OPERATING INSTRUCTIONS

Power On

- Turn on the power by pressing the power button for 2 seconds. Once it is on, the unit begins to auto-check and count down from 0-9 before entering the weighing mode
Note: Anything on the scale before powering on will automatically be tared out.

Zero

- Zero is only used when the scale is supposed to be empty
- Pressing the ZERO key will reset your scale to 0
- Depending on what your manual zero range parameter is set to, you can zero out any number within the range, after that you will receive an error and will need to tare out the weight

Unit Selection

To switch between measuring units (lb/kg or lb/kg/g/oz/lb:oz) press the UNITS key

Tare Function

- Tare is used when you only wish to see the current change in weight, not the total weight
- When the indicator is in gross mode (gross light is shown) pressing the TARE key will Tare the current weight on the scale and enter the net mode (net light shown)
For example, add a container to the scale, press tare and the display will show the tare symbol and reset back to 0. Now add the product to the container, it will only display the weight of the product, not the container.
- To exit Tare mode, press the TARE key again to enter gross mode and you will see the total weight of the container and the product

Note: If you remove the container, the scale will display weight less that of the container.

Hold

There are 3 different hold functions you can choose from in the C11 parameter

1. Peak Hold: Grabs the highest weight (for materials testing, ie. tension and pulling force)
 - Press the HOLD key then add weight to the scale
 - The indicator will show the highest weight it recorded and hold it on the screen until a higher weight is placed on the scale
2. Manual Hold: Grabs the current weight and holds it so it will not change/fluctuate
 - While weighing, press HOLD and the indicator will hold the current weight on the screen until HOLD is pressed again
3. Average Hold: Used for weighing animal, the indicator will display the average weight sampled from 3 seconds
 - Add livestock to scale and press HOLD
 - Indicator screen will show "LOC" for 3 seconds, then display the average weight from those 3 seconds
 - Press HOLD again to exit holding mode

Print





- If the indicator is connected to a printer and the weight on the scale is stable press the PRINT key to print the current weight

CALIBRATION PROCEDUER

How to enter

1. Turn on the scale by holding **ON/OFF** for 2 seconds
2. Press **HOLD** and **PRINT** together to access the setup menu.

Available Keys

-  Move to the right by 1 place of the set value
-  Increase the set value
-  Reduce the set value
-  Exit current menu
-  Move into next menu

Calibration Menu

1. Turn on the scale by holding **ON/OFF** for 2 seconds.
2. Press **HOLD esc** and **PRINT enter** together to access the setup menu.
3. If done correctly, the display should now show **C01**.
4. Press **PRINT enter** to access the C1 channel. The display should show [**C1 #**].
5. Press **ZERO ▲** to choose which unit you want to calibrate in (1 = kg, 2 = lb).
6. Press **PRINT enter** to set the value. The display will now show **C02**.
7. Press **PRINT enter** to access the C2 channel. The display should show [**C2 #**].
8. Press **ZERO ▲** to change the setting to the decimal places desired (The C2 channel is used to adjust the decimal point on the scale. A value of 1 means there is one digit behind the decimal point.)
9. Press **PRINT enter** to set the value. The display will now show **C03**.
10. Press **PRINT enter** to access the C3 channel. The display should show [**C3 #**].
11. Press **ZERO ▲** to cycle through the values until the desired graduation appears. (The C3 channel adjusts the divisions on the scale. A value of 1 selected and C2 set to 1, the scale will read in 0.1 lb. increments.)
12. Press **PRINT enter** to set the value. The display will now show **C04**.
13. Press **PRINT enter** to access the C4 channel. The display will show [#####].
14. Enter in the maximum capacity you want to use for this scale by using **UNITS ►** to move the cursor right, and **TARE ▼** and **ZERO ▲** to move the values down and up. (The C4 channel is used to enter in the max capacity of the scale; Make sure this doesn't exceed the max capacity of the scale; Max capacity divided by the increment set in C02 and C03 above cannot exceed 5000.)
15. Press **PRINT enter** to set the value. The display will now show **C05**.
16. Press **PRINT enter** to access the C5 channel. The display should show [**C5 #**].
17. The C5 channel calibrates zero on the scale. Make sure the scale is empty.
18. Press **ZERO ▲** to change the value to 1.
19. Press **PRINT enter**. The display will count down from 10-1 while the scale is calibrating zero. When the display shows 0 the zero calibration is complete.

The indicator offers 2 calibration methods, Single Point which uses one weight to calibrate or Linear Calibration, which uses multiple (2-7) weights for a more accurate calibration.

To Calibrate using only 1 calibration weight (Single Point Calibration)

20. Press **PRINT enter** to continue. The display will now show **C06**.
21. Press **PRINT enter** to access the C06 channel. The display will show [**C6 0**].
22. The C6 channel is used to calibrate the scale with a known weight. Press **ZERO ▲** to set the value of C6 to [**C6 1**]. Press **PRINT enter**. The display will flash **SPAN**, and then show [#####].

23. Enter the calibration weight value you will use (at least 10% of max capacity you set in C04 by using **UNITS** ► to move the cursor right, and **TARE** ▼ and **ZERO** ▲ move the values down and up.)
24. Place the calibration weight you have on the empty scale and press **PRINT enter**.
25. The scale will count down from 10 to 0. Once 0 has been reached, the display will show **[CALEnd]**.
26. Press **PRINT enter** to set the value. The display will now show **[07]**.
27. Press **HOLD esc** to save and exit the setup menu.
28. The scale has now been calibrated. The display will show the value of the calibration weight on the scale.
29. If the scale does not show the value of the calibration weight, check that the feet on the platform are not screwed in too tightly, and verify that the platform is level.
30. Unload the scale; the display should read **000000**.
31. If the scale does not display 000000, check that the feet on the platform are not screwed in too tightly, and verify that the platform is level.

To Calibrate using only multiple calibration weights (Linear Calibration)

1. Press **PRINT enter** to continue. The display will now show **[C06]**.
2. Press **PRINT enter** to access the C06 channel. The display will show **[C6 0]**.
3. The C6 channel is used to calibrate the scale with a known weight. Press **ZERO** ▲ to set the value of C6 to **[C6 2]**. Press **PRINT enter**. The display will flash **SPAN**, and then show **[LnE 2]**.
4. Press **ZERO** ▲ to enter the number of weights you want to use (2-7); the more you use, the more accurate the calibration will be. (an example of 2 will be used).
5. Press **PRINT enter** to set your value. The screen will flash **[dbno01]** then **[000 100]**.
6. Enter the lowest calibration weight value you will use (at least 10% of max capacity you set in C04) by using **UNITS** ► to move the cursor right and **TARE** ▼ and **ZERO** ▲ move the values down and up.
7. Place the calibration weight you have on the empty scale and press **PRINT enter**.
8. The scale will count down from 10 to 0. Once 0 has been reached, the display will show the screen will flash **[dbno02]** then **[000200]**.
9. Enter the next calibration weight value you will use by using **UNITS** ► to move the cursor right, and **TARE** ▼ and **ZERO** ▲ move the values down and up.
10. Place the calibration weight you have on the empty scale and press **PRINT enter**.
11. The scale will count down from 10 to 0. Once 0 has been reached, the display will show the screen will show **[CALEnd]**.
12. Then follow steps 26-31 on the single point calibration instructions.

INDICATOR PARAMETER SETTINGS

The parameter settings menu has a calibration section (C01 to C07 explained above) and a parameter settings section (C08 and up).

To access the calibration section the seal switch (located at one corner of the PCB) must be OFF. This will allow access to all C01 and up settings. If the seal switch is ON, then only C08 and up can be accessed by the user. If you break the official seal by opening the back of the indicator to access the seal switch, you may need to have the indicator recertified. Be sure to adjust the seal switch back to the original setting after calibration/configuration has been performed.

To enter calibration/parameter settings, follow the procedure below:

1. Make sure UNITS is set to either kg or lb
2. Press and hold **HOLD** and **PRINT** key at the same time for 2 seconds
3. Navigate through the settings (C01 to C45) as shown in the table 4 below by using the arrow keys and return keys as labeled under each indicator button
4. Press **PRINT** key to enter/edit the parameter setting
5. Press **PRINT enter / HOLD esc** key to save and exit settings at any time

Function	Parameter	Settings/Options										
Weighing Unit	C01	<table style="width: 100%; border: none;"> <tr> <td style="width: 50%;">Model 1</td> <td style="width: 50%;">Model 2</td> </tr> <tr> <td>1 = kg</td> <td>1 = kg</td> </tr> <tr> <td>2 = lb</td> <td>2 = lb</td> </tr> <tr> <td></td> <td>3 = gram</td> </tr> <tr> <td></td> <td>4 = oz</td> </tr> </table> <p>Note: for calibration only kg or lb are allowed</p>	Model 1	Model 2	1 = kg	1 = kg	2 = lb	2 = lb		3 = gram		4 = oz
Model 1	Model 2											
1 = kg	1 = kg											
2 = lb	2 = lb											
	3 = gram											
	4 = oz											
Decimal Setting	C02	0 = no decimal 1 = 0.0 2 = 0.00 3 = 0.000 4 = 0.0000										
Graduation Setting (readability of the least significant digit)	C03	options: 1/2/5/10/20/50 Example with no decimal places (ie. C02=0) 1 = 1 lb 2 = 2 lb 5 = 5 lb 10 = 10 lb 20 = 20 lb 50 = 50 lb										
Maximum Capacity	C04	set max capacity										
Zero Calibration	C05	0 = zero calibration not needed 1 = set the zero calibration (Please ensure scale is empty and the stable light is on)										
Calibration	C06	0 = calibration not needed 1 = Ready to calibrate with one calibration weight 2 = Ready to calibrate using multiple calibration weights (Linear) 3 = Sensitivity Output										

Function	Parameter	Settings/Options
Restore Default Settings	[07]	0 = do not restore 1 = restore to default settings
Warning Tone	[08]	0 = turn off warning tone 1 = turn on warning tone
Automatic Power Off	[09]	0 = turn off auto power off 10 = power off automatically if no change within 10 minutes 30 = power off automatically if no change within 30 minutes 60 = power off automatically if no change within 60 minutes
Power Saving Mode	[10]	LED Version OP900A: 0 = turn off power saving setting 3 = turn off display if no change within 3 minutes 5 = turn off display if no change within 5 minutes
Hold Function	[11]	0 = turn off hold function 1 = Peak hold - Grabs the highest weight 2 = Manual hold - Grabs the current weight 5 = Auto Average hold - Average hold without the need to press the hold key
Unit Conversion	[12]	* See table 2
Upper Limit Alarm	[13]	Set upper limit within the max. capacity
Lower Limit Alarm	[14]	Set lower limit within the max. capacity
Inner Code Display	[15]	check the inner code [raw data]
Set Date	[16]	Set date from left to right: year/month/day
Set Time	[17]	Set the time from left to right: hour/minute/second
Communication Setting	[18]	Set the serial interface data output method: 0 = Turn off serial interface data output 1 = Continuous sending mode, for remote display 2 = Print to paper thermal ticket printer 3 = Command request mode, for computer. 4 = PC continuous sending mode, for computer 5 = PC/remote display, continuous sending mode 6 = Print to adhesive label thermal printer 7 = Print to Zebra/large adhesive label thermal printer 8 = Reserved
Baud Rate	[19]	0 = 1200 (for OP-910 remote display) 1 = 2400 2 = 4800 3 = 9600 (for all printers and OP-910X, OP-910XL remote display) 4 = 14400
Manual Zero Range	[20]	0 = turn off manually zero setting 1 = ±1% max capacity 2 = ±2% max capacity 4 = ±4% max capacity 10 = ±10% max capacity 20 = ±20% max capacity 100 = ±100% max capacity

Function	Parameter	Settings/Options
Initial Zero Range	C21	0 = no initial zero setting 1 = ±1% max capacity 2 = ±2% max capacity 5 = ±5% max capacity 10 = ±10% max capacity 20 = ±20% max capacity 100 = ±100% max capacity
Zero Tracking	C22	0 = turn off zero tracking 0.5 = ±0.5d 1.0 = ±1.0d 2.0 = ±2.0d 3.0 = ±3.0d 4.0 = ±4.0d 5.0 = ±5.0d Note: zero tracking range cannot be bigger than manual zero range d = division
Zero Tracking Time	C23	0 = turn off zero tracking time 1 = 1 second 2 = 2 seconds 3 = 3 seconds
Overload Range	C24	00 = turn off overload range 01-99d = overload range setting d = division
Negative Display	C25	0 = -9d 10 = -10% max. capacity 20 = -20% max. capacity 50 = -50% max. capacity 100 = -100% max. capacity
Standstill Time	C26	0 = quick 1 = medium 2 = slow
Standstill Range	C27	1 = 1d 2 = 2d 5 = 5d 10 = 10d d = division
Digital Filter (for filtering moving items such as animals)	C28	0 = turn off dynamic filter 1 = 1 digital filter strength 2 = 2 digital filter strength 3 = 3 digital filter strength 4 = 4 digital filter strength 5 = 5 digital filter strength 6 = 6 digital filter strength 7 = 7 digital filter strength 8 = 8 digital filter strength 9 = 9 digital filter strength Note: The higher the number, the higher the filter strength
Noise Filter	C29	0 = turn off noise filter 1 = 1 digital filter strength 2 = 2 digital filter strength 3 = 3 digital filter strength

Function	Parameter	Settings/Options
Print Time and Date	[30]	0 = yy.mm.dd 1 = mm.dd.yy 2 = dd.mm.yy 3 = yy.mm.dd
Analog Output Setting	[31]	0 = 0 - 5V output 1 = 4 - 20mA output
Calibrate Current	[32]	4 - 20mA current
Relay Output Setting	[33]	0 = turn off relay output 1 = turn on relay output function 1 2 = turn on relay output function 2 3 = Reserved menu
Zero Setting	[34]	0 = Back to zero 1 = Press ZERO and PRINT together to back to zero.
Gravity of Calibration Location	[36]	9.7000 - 9.9999
Gravity of Destination	[37]	9.7000 - 9.9999
Version No.	[38]	
Weight reversed setting	[39]	0 = normal weight 1 = weight reversed
Print Mode	[41]	0 = auto mode 1 = gross mode 2 = tare mode
Print Carriage Return	[42]	0 - 9 (How much space between print outs)
Space Print	[43]	0 - 9 (Where the data prints on the paper: 0 = left ; 9 = right)
Date Print	[44]	0 = do not print the date 1 = print date the date
Time Print	[45]	0 = do not print the time 1 = print-the time
LED Display Brightness	[49]	0-7 Brightness increased

Table 2. Unit Conversion Parameter Settings

Model 1

Parameter Settings	Units Available
[01] = 1 & [12] = 0	kg only
[01] = 1 & [12] = 1	kg / lb
[01] = 1 & [12] = 2	kg / lb
[01] = 1 & [12] = 3	kg / lb
[01] = 1 & [12] = 4	kg only
[01] = 2 & [12] = 0	lb only
[01] = 2 & [12] = 1	lb / kg
[01] = 2 & [12] = 2	lb / kg
[01] = 2 & [12] = 3	lb / kg
[01] = 2 & [12] = 4	lb only

Model 2

Parameter Settings	Units Available
[01] = 3 & [12] = 0	oz only
[01] = 3 & [12] = 1	lb / kg
[01] = 3 & [12] = 2	g / oz / lb-oz
[01] = 3 & [12] = 3	lb / kg / g / oz / lb-oz
[01] = 3 & [12] = 4	lb only

Table 3. Default Parameter Settings

Function	Parameter	Default Setting
Weighing Unit	C01	1
Decimal Setting	C02	0
Graduation Setting	C03	1
Maximum Capacity	C04	100000
Zero Calibration	C05	0
Calibration	C06	0
Restore Default	C07	0
Warning Tone	C08	1
Automatic Power Off	C09	0
Power Saving Mode	C10	0
Hold Function	C11	0
Unit Conversion	C12	1
Upper Limit Alarm	C13	000000
Lower Limit Alarm	C14	000000
Inner Code Display	C15	
Set Date	C16	
Set Time	C17	
Communication Setting	C18	1
Baud Rate	C19	3 (9600)
Manual Zero Range	C20	10
Initial Zero Range	C21	10
Zero Tracking	C22	1.0
Zero Tracking Time	C23	3
Overload Range	C24	9
Negative Display	C25	10
Standstill Time	C26	1
Standstill Range	C27	2
Digital Filter	C28	3
Noise Filter	C29	2
Print Time and Date	C30	0
Analog Output Setting	C31	1
Relay Output Setting	C33	1
Multi-connection add.	C34	0
Wireless Communication	C35	6
Gravity of Calibration Location	C36	9.7936
Gravity of Destination	C37	9.7936
Print Mode	C41	0
Print Carriage Return	C42	2
Space Print	C43	0
Date Print	C44	1
Time Print	C45	1
LED Display Brightness	C49	4

CONNECTORS

1. Load cell connection

- The indicator can work with up to 8 load cells of 350Ω
- Either 4 wire or 6 wire load cell connection
- Please contact us directly if you have other special needs for your applications
- There are two connection methods between the load cell and indicator

Quick Disconnect as shown below:

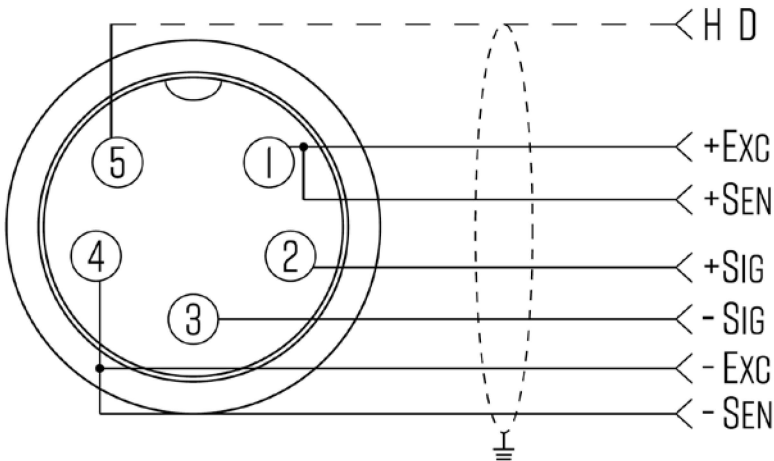

FIGURE 2: QUICK DISCONNECT CONNECTION DIAGRAM

Hardwire (Using Inner Terminal Block Connection:

Note: Make sure you follow all the anti-static rules to avoid damage to your indicator

- Excitation voltage: 5VDC
- Largest output current: 120 mA
- Excitation circuit: 5 VDC, 4 wire connection, 8 load cell of 350ohm maximum
- Open the back cover of the weighing indicator, and insert signal cable to the terminal block (see figure 3); Make sure the screw on terminal block is fixed tightly

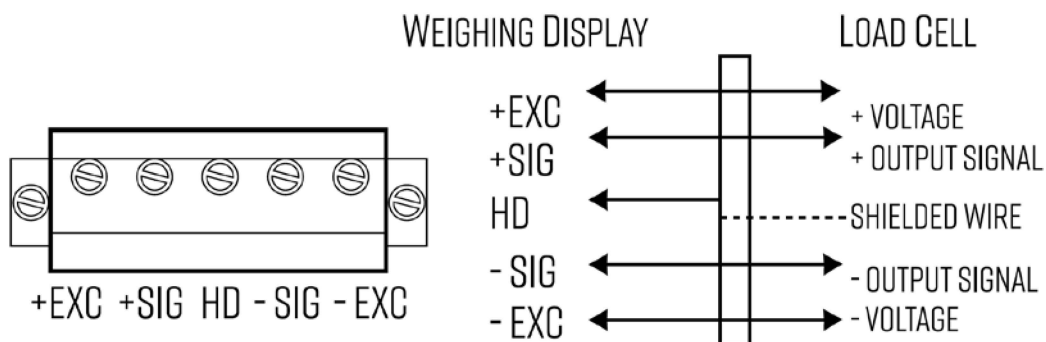

FIGURE 3: INNER TERMINAL BLOCK CONNECTION DIAGRAM

Table 4. Wiring Color Code

Signal Name	Color Code	Description
+Exc/ +EX	RED	Positive excitation voltage to load cell
+IN / +SIG	GREEN	Positive output signal from load cell
HD / SHLD	YELLOW/THICK BLACK	Shield Wire
-IN / -SIG	WHITE	Negative output signal from load cell
-EXC / -EX	BLACK	Negative excitation voltage to load cell

2. RS-232 Connection (DB9 9 pin Connector)

The DB9 9 pin serial connector is used for different purposes depending on the indicator model

- Figure 4 shows the pin assignment on the DB9 9 pin connector

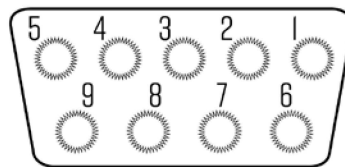

FIGURE 4: DB9 SERIAL CONNECTOR PINOUT

RS232 SERIAL OUTPUT FORMAT

Follow the pin out of Table 5 below to connect the indicator the RS-232 Serial device

Table 5. DB9 Pin Description

DB9 Pin	Definition	Function
2	TXT	Transmit Data
3	RXD	Receive Data
5	GND	Ground Interface

The serial output format depends on the settings for parameter C18. The serial output consists of a string of ASCII characters. Here is a list of the serial parameters

- 8 data bits
- 1 stop bits
- No parity
- No handshaking

Remote Display Continuous Sending Mode (C18=1)

For use with a Scoreboard/Remote Display Note: Baud Rate must be set to 1200 (C19 = 0)

Output Continuous Format																	
S T X	S W A	S W B	S W C	X	X	X	X	X	X	X	X	X	X	X	X	C R	C K S
1	2		3				4				5	6					

State A			
Bits0,1,2			
0	1	2	Decimal point position
1	0	0	XXXXXX0
0	1	0	XXXXXX
1	1	0	XXXXX.X
0	0	1	XXXX.XX
1	0	1	XXX.XXX
Bits3,4			Division
0	1		X1
1	0		X2

State B	
BitsS	function
Bits0	gross=0, net=1
Bits1	Symbol: positive=0, negative=1
Bits2	Overload (or under zero)=1
Bits3	dynamic=1
Bits4	unit: lb=0, kg=1
Bits5	Constant 1
Bits6	Constant 0

State C			
Bit2	Bit1	Bit0	unit
0	0	0	Kg or lb
0	0	1	g
0	1	0	t
Bit 3			printing=1
Bit 4			Extend display=1
Bit 5			Constant 1
Bit 6			Constant 0

PC or Remote Display Continuous Sending Mode (C18=5)

<STX>	<POL>	XXXXX.XX	<L/K>	<G/N>	<STAT>	<CR>	<LF>
Start Transmission	Weight Data		Gross/Net: GR = Gross		Carriage Return		
	Polarity: <SP> = Positive "- " = Negative	Units: lb = punt kg = kilogram pcs = pieces*	NT = Net	Status: <SP> = Valid M = Motion O = Over/under range	Line Feed		

Print to Adhesive Label Printers (C18=5) & (C18=6)

Printing formats:

Date:	05/01/2017
Time:	11:30:52
Net:	25.6lb
Tare:	10.3lb
Gross:	35.9lb

Date:	XX.XX. XX (yy.mm.dd)
Time:	XX.XX.XX (hh.mm.ss)
NET	6.00kg (net weight)
TARE	2.88kg (tare)
GROSS	8.88kg (gross weight)

TROUBLESHOOTING

Issues/Error Codes	Possible Causes	Suggested Actions
Scale does not turn on	<ol style="list-style-type: none"> 1. Loose power cord 2. Outlet is defective 	<ol style="list-style-type: none"> 1. Ensure the power cord is plugged in 2. Ensure the power source works. Test the power source by connecting a different appliance to the same outlet to check if it's operational.
The reading goes negative when a load is applied	<ol style="list-style-type: none"> 1. The Sig+ and Sig- wires are connected to the wrong ends of the load cell 	<ol style="list-style-type: none"> 1. Try switching the Sig+ and Sig- wires connected to the load cell and/or the junction box (if one is used)
	<ol style="list-style-type: none"> 1. Overload 2. Cables are not connected properly 3. Load cell is defective 	<ol style="list-style-type: none"> 1. Reduce the weight 2. Check load cell connection 3. Inspect load cell; Check the input/output 4. If the above actions don't work, try the following instructions: <ol style="list-style-type: none"> 1. Check if the cable that runs from the indicator to the junction box is damaged. If it is, replace the cable. 2. Check for any water damage inside the junction box. If there is, replace the junction box 3. Ensure all wires on all 5 terminal blocks are not loose. Retighten the screws if needed. 4. Recalibrate 5. If none of the above works, one or more load cells may be defective

<p>nnnnnnnn</p>	<ol style="list-style-type: none"> 1. Calibration is no good 2. Cables are not connected properly 3. Load cell is defective 	<ol style="list-style-type: none"> 1. Ensure scale is leveled 2. Check load cell connection 3. Check load cell input and output resistance 4. If the above actions don't work, try the following instructions: <ul style="list-style-type: none"> • Check if the cable that runs from the indicator to the junction box is damaged. If it is, replace the cable. • Check for any water damage inside the junction box. If there is, replace the junction box • Ensure all wires on all 5 terminal blocks are not loose. Retighten the screws if needed. • Recalibrate 5. If none of the above works, one or more load cells may be defective
<p>Err 1</p>	<p>No weight was used during calibration or the weight used was above the max capacity.</p>	<p>Use correct weight within the defined range</p>
<p>Err2</p>	<p>The weight used during calibration was below the minimum required weight.</p>	<p>The calibration weight minimum is 10% of the maximum capacity set in C04. It is recommended to use 60%-80% of the maximum capacity.</p>
<p>Err3</p>	<p>During calibration, the input signal is negative</p>	<ol style="list-style-type: none"> 1. Check all wire connections 2. Check load cell for damages 3. Recalibrate 4. If none of the above works, the PCB may need to be replaced
<p>Err4</p>	<p>Signal is unstable during calibration</p>	<p>Start calibration after the platform is stable</p>
<p>Err5</p>	<p>EEPROM Error</p>	<p>Replace the PCB</p>

<p>Err6</p>	<p>Exceed Zero Range</p>	<ol style="list-style-type: none"> 1. Check cables for any indentations, crimps, or cuts. 2. Check your scale for damages. 3. Try calibration first Press and hold the HOLD and PRINT button at the same time for 3 seconds to get into calibration mode. C01 should appear. 4. With C01 on the screen press the PRINT button. On the left side of the screen should show C1 and on the right side be a 1. (C1 1) 1 is the default unit of measurement of Kg. Press the ZERO button to make that 1 to a 2. (C1 2) 2 stands for lbs. 5. Press the PRINT button. C02 should appear. Press the PRINT button. (C2 0) should appear. The 0 is the number of decimal places you are weighing in. Press the PRINT button. C03 should appear. 6. Press the PRINT button. (C3 1) should appear. The 1 stands for 1 graduation setting. This means the weight would increment by 1 lb. Press Print C04 should appear. Press the PRINT button. 7. 100000 should appear. This is the Max Capacity of your scale. Press the PRINT button. C05 should appear. Press the PRINT button. 8. (C5 0) should appear. This is the zero calibration. Clear the scale and make sure the feet are attached. Press the ZERO button to make the 0 to 1. (C5 1) appears. Press the PRINT button. (CAL 10) to (CAL 9) ... to (CAL 1). 0 should appear. 0 is a good sign. Press the PRINT button. C06 should appear. 9. Press the PRINT button. (C6 0) should appear. This is where your calibration weight of at least 10% of max capacity is going to be used. I am using my weights for this example of 150 lbs. Press the ZERO button to make the 0 into a 1. (C6 1) will appear. Press the PRINT button. SPAn will appear followed by 010000. 10. You will now enter your weight to calibrate. If (000001) was on the screen and I wanted it to be (000000) press the TARE button to decrement the value. Moving left by pressing the UNITS button multiple times to the tenth's place will start blinking. In my example, I keep pressing the ZERO button until (000050) appears. Match the number on the screen to the weight you are using. Place the weight on the scale. With the weight on the scale and the matching weight on the screen press the PRINT button. CAL 10, CAL 9, CAL 8... to CAL 0 would appear with some number on the screen. Then CAL End will appear. Remove weight from the scale. 11. Press PRINT on the CAL End screen. C07 will appear. With nothing on the scale press the HOLD button. You are done with calibration.
-------------	--------------------------	---