

T903

Portable Static Weighing Indicator

User's Manual



(4 Channels)

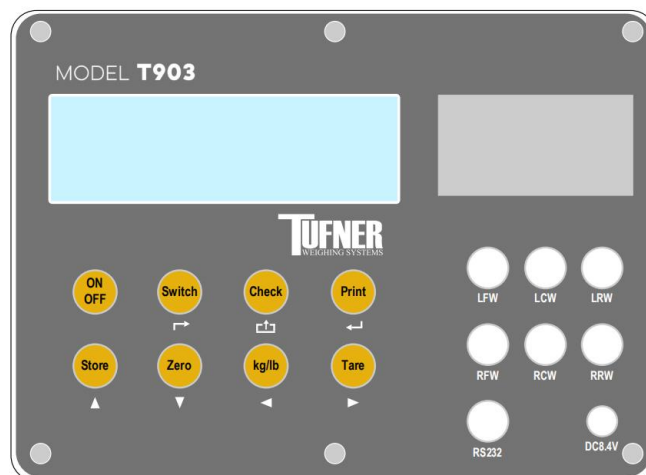

(6 Channels)





Safety Instruction

For safety operation pls. follow the safety instruction.



WARNING

Setting, Calibration Inspection and Maintain of the indicator is prohibited by Non-professional staff.



WARNING

Pls. make sure the weighing display have good ground in using.



WARNING

The indicator is the static and sensitive equipment, cut off the power during electrical connections, internal components touched by hand is prohibited, and please take the measure of anti-static.

LIST

LIST.....	1
1. PRODUCT INTRODUCTION.....	1
1.1 MAIN FUNCTION.....	1
1.2 TECHNICAL PARAMETER.....	1
1.3 DRAWING.....	2
1.4 BATTERY INSTRUCTION.....	2
2. INSTALLATION AND CALIBRATION.....	2
2.1 CHECK.....	2
2.2 POWER SUPPLY CONNECTION.....	2
2.3 CONNECTION OF LOAD CELL AND INDICATOR.....	3
2.4 COMMUNICATION INTERFACE.....	4
3. BASIC OPERATION.....	5
3.1 KEYPAD.....	5
3.2 POWER ON & OFF.....	6
3.3 ZERO OPERATION.....	6
3.4 TARE OPERATION.....	6
3.5 UNIT SWITCH.....	7
3.6 CHECKING.....	7
3.7 SWITCHING.....	7
3.8 PRINTING.....	7
4. CALIBRATION AND PARAMETER SETTING.....	7
4.1 ENTER SETTING.....	7
4.2 STEP OF CALIBRATION OPERATION.....	8
4.3 APPLICATION FUNCTION PARAMETERS SETTING CHART.....	9
5. SERIAL INTERFACE RECEPTION COMMAND.....	11
5.1 COMMAND 1.....	11
5.2 COMMAND 2.....	12
6. PRINT FORMAT.....	12
6.1 NORMAL PRINTING FORMAT.....	12
6.2 ACCUMULATIVE PRINTING FORMAT.....	12
7. MAINTENANCE.....	13
7.1 REGULAR ERROR AND SOLUTION.....	13
7.2 DAILY MAINTAIN.....	14
7.3 PACKING LIST.....	15

1. Product Introduction

1.1 Main Function

Portable Static Weighing Indicator MWI01 is designed for static axle scale. It can connect with 1,2,3,4,5,6 weighing pads to weigh the truck. It owns manual weighing mode and automatic weighing mode. It can be normal weighing or accumulative weighing. Varied weighing ways to meet different requirements.

LCD display (size: 136mm x 36.5mm) show the real weight date on the weighing pad. The unit KG/LB display can be adjusted by the key on the instrument. At same time, the percentage of each pad on the total weighing is displayed too. Other function includes tare, zero, print, save, check, delete.

The power supply by 7.4v/4400mAh battery and it can be recharged by 8.4v/1A adapter. Built-in thermal printer, several printing formats; with RS232 interface for computer; The calendar is in the software. Date and time can be checked easily. Easy operation, high precision, good application.

1.2 Technical parameter

>> Sensitivity	0.5uv/d
>> Input voltage	-30- 30mV
>> Accuracy class	III
>> Initial zero range	±10%Max
>> Manually zero range	±2 ‰ Max
>> Zero Range	100% Max
>> Zero Tracking	0.5 t/s
>> Excitation circuit	VDC ,6 wire connection,Maximum connect 24 load cell of 350Ω
>> AC power	100~240VAC,50/60HZ
>> Operation temperature humidity	-10°C ~ +40°C,≤90%RH
>> Storage temperature	-10°C ~ +40°C

1.3 drawing



1.4 Battery instruction

1. when you use the internal battery first time, you should charge the battery fully, to prevent low voltage resulted from self leakage of battery.

2. when the “” is flashing, it means low battery, pls. charge it in time.

3. when  and no flashing, it means fully charged

4. if battery is not used for long time, take it out to avoid the leakage.

5. In order to keep the battery in best using condition, it is suggest that you fully discharge the battery every month, the method is that using the indicator till it is automatically power off.

2. Installation and calibration

2.1 Check

Open the box and check all items according to the packing list. If som missed or broken, please contact with our company immediately.

2.2 Power supply connection

The indicator is powered by adapter, you plug the adapter directly into the “DC” pin at the back cover the indicator is ok.

2.3 Connection of load cell and indicator

The indicator can connect with 4 weighing pads or 24 pcs of load cells 350Ω at most. Quick disconnect of load cell as below.

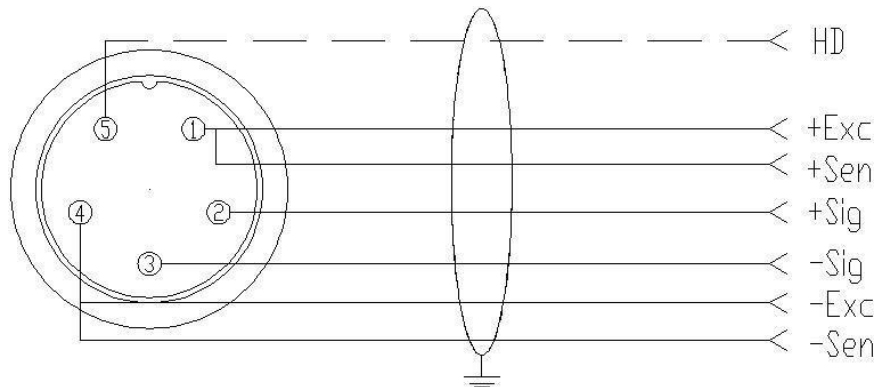

The number of weighing pads and load cells correspond to the weighing modes. If the pads or load cells are connected at the right way, the indicator can't work. Please pay attention to the below.

Number of weighing pad	Load cell connection	Weighing mode
1	LFW	[ModE 1]Setting "1"
2	LFW,RFW	[ModE 2]Setting "2"
3	LFW,LRW,RRW	[ModE 3]Setting "3"
4	LFW,RFW,LRW,RRW	[ModE 4]Setting "4"
5	LFW, RFW, LRW, RRW, LFW/RFW	[ModE 5]Setting "5"
6	LFW, RFW, LRW, RRW,LFW/RFW,RFW/LRW	[ModE 6]Setting "6"

Normal weighing mode and accumulative weighing mode can work with the printer to print the weighing data.

Normal Weighing mode:

To set the printing format "1", the indicator is in normal weighing mode. It can connect 1/2/3/4/ pads to weigh and "Print" the weighing data and save.

Example:3 weighing pads connect with indicator to weigh the airplane.

- The pads should connect with LFW,LRW,RRW interfaces;
- parameter setting:working mode[ModE 3]setting "3";printing format[PF - 1]setting "1";
- Drive the plane on the pads. Press "switch" button, indicator can display the total weight and the weight of each pad and the percentage of each pad weight from the total weight.If printing format setting"1", the weighing data can print automatically and save after stable.If printing format setting"0", the weighing data will print and save manually.

Accumulative weighing mode:

To set printing format "2", the indicator is in accumulative weighing mode. Now 2/4

pads should be connected with the indicator. And press "store" button to accumulate the axle weigh and print. Then press "printing" to print the final accumulative weight and

save.

Example:Two pads work with the indicator to weigh a truck with three axles.

- a. The pads should connect with LFW,RFW interfaces;
- b. Parameter setting:working mode[ModE 2] setting“2”;printing format[PF - 2]setting“2”;Axles [ALE - 3]setting“3”.
- c. Drive the first axle of the truck on the weighing pads. Press “Switch” button, indicator can display the axle weight and the each weight of the wheels and the percentage of each wheel weight from the axle weight. If printing format setting “1”, the weighing data can print and save automatically after weighing stable;If printing format setting“0”, the weighing data will print and save manually by press “ store” button.
- d. Drive the second axle of the truck on the weighing pads and repeat the operation same as step C, accumulate and print the second axle weight.
- e. Drive the second axle of the truck on the weighing pads and repeat the operation same as step C, accumulate and print the third axle weight.
- f. After finishing the weight for three axles, if printing format setting“1”, the total weight will print and save automatically; If printing format“0”, it will print manually by press “print” button.

2.4 Communication interface

RS232 :DB9 Pin definition as below.

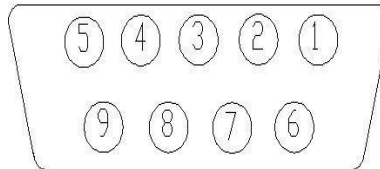

Pin function and definition as bellows:

DB9 joint	Definition	Function
2	TXD	Sending data
3	RXD	Receiving data
5	GND	Ground interface

3. Basic operation



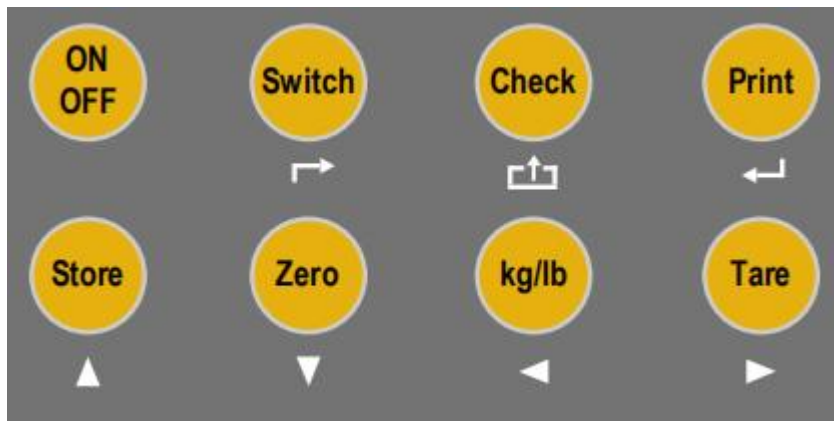



3.1 Keypad



LCD	Instruction
	Weighing data
Kg/lb	Weighing unit: kg/lb
	Percentage, show how many percentage the pad weight take on the whole weight
Tare	Tare
Gross	Gross weight
Net	Net weight
	The weighing data is stable
	Weight is zero
LFW	The weight of the left front wheel
RFW	The weight of the right front wheel
LRW	The weight of the left back wheel
RRW	The weight of the right back wheel
Total	Go to accumulation mode

Keys function

keys	Key name	Key function
	Print	1. Printing the weighing data as weighing. 2. Working with the switch button to get into the menu of calibration.
	Store	In accumulative weighing mode, to accumulate the axle weight and print the weight data.

	Zero	Zero the weight within tolerance
	Tare	At G.W mode, get the tare weight. At N.W mode, clear the tare, get the G.W
	Kg/lb convert	Covert between kg and lb
	Check	Check and read the saved weight data to print.
	Switch	Switch the weight between the pad weight and the total weight.
	Power on/off	Press 2 seconds to power on or power off

3.2 Power on & off

Press the "on/off" key for 2 seconds in the shutdown state, and the indicator will start automatically; Press the "on/off" key for 2 seconds when the indicator is powered on. When the indicator is powered on, you can check whether there are abnormal strokes or LCD status indications according to the display, and then enter the weighing state.

3.3 Zero operation

Within the tolerance, "Zero" key clear the weight on all weighing pads. When the pads unstable or loading over zero range or on tare mode, indicator can't ZERO and show ERROR.

3.4 Tare operation

In normal weighing mode, press "Tare" button to make the load be tare weight; In accumulative weighing mode, press "Tare" button to preset the tare weight and press " print" button to confirm the tare weight. The lights on the keypad is showing. In Tare mode, press "Tare" button to deduct the tare weight from the total weight and show the net weight.

NOTE:Tare mode only show on the total weight display.

3.5 Unit Switch

To press “Unit” button for switching the unit between “KG” and “LB”.

3.6 Checking

Weighing mode, press “Check” button to show “C 0030” (30 records existing), input “C 0020” and press “ Print” to check 20th record. Display show “REAd-0”. Choosing”1” to show date, time, axle, tare weight and total weight one by one. Then “Print 0”, choosing “1” to print this record and back to the Checking display “C 0020”. Press “Check” Button again to quit and back to weighing mode.

3.7 Switching

Weighing mode, press “Switch” button to change the display between the axle weight and the total weight.

3.8 Printing

Manual weighing, press “print” button to print when the pad is stable.

Note:

1. Automatic accumulative weighing mode, press “Print” to print the total weight even if the number of axle don’t reach the setting number.
2. Press”store”and “print”,to add the current weight data printing.

4. Calibration and Parameter setting

4.1 Enter setting

Press “ Switch” button 3-5 seconds to enter into the menu for setting F1-F5.

The key functions in setting:



ENTER ▲ UP





















DOWN ► LEFT

 RIGHT

 EXIT THE MENU

4.2 Step of calibration operation













F1 menu: setting working mode, unit, decimal, graduation and span.

Step	Operation	Display	Remark
		[F 1]	F1 menu
1	press 	[Mode 2]	Weighing pad working mode: 1/2/3/4
2	press  or  press  to skip	[CAL--0] [CAL--1]	Zero Calibration: 0=Zero calibration is not performed. 1=Perform zero calibration.
3	press  or  Press  Or press  to skip	[dot--2]	Point number: 0/1/2/3/4
4	press  or  press 	[E - 05]	Graduation setting: 1,2,5,10,20,50.
5	press  or  press 	[Full-0] [Full-1]	0:no change of max capacity 1:change the max capacity
6	press  or  or  or  press 	[0500.00] [1000.00]	Setting the max span Default division: 10000, display 500.00. The max. span is 1000.00

F2 menu: Zero, loading calibration, save the calibration parameter.

















Step	Operation	Display	Remark
		[F 2]	F2 menu
1	press 	[SCALE1] [SCALE2] [SCALE3] [SCALE4] [SCALE5]	Pad choose: calibration for the 1st pad Pad choose: calibration for the 2nd pad Pad choose: calibration for the 3rd pad Pad choose: calibration for the 4 th pad Pad choose: calibration for the 5 th pad





























		[SCALE6]	Pad choose:calibration for the 6th pad
2	press ▲ or ▼ press ↵	[CAL--0] [CAL--1]	Zero Calibration: 0=No need calibration 1= need calibration

	or press  to jump		
3	press  or  press  or press  to jump	[SPAN-0] [SPAN-1]	0=No need loading calibration 1=loading calibration
	press  or  /  or  press 	[0100.00]	Loading calibration: Setting loading 100,00 and put the 100kg weight on the 2 nd pad. Loading choice: load the weight as possible As max capacity, at least 10%
4	press  or  press 	[SAVE-0] [SAVE-1]	0=non-save the loading parameter 1=save the loading parameter







F2 can set the mode(channel) to 0, so that all channels can be zeroed with one key, and then each channel can be calibrated separately





4.3 Application function parameters setting chart

Step	Operation	Display	Remark
		[F 3]	F3 menu
1	press 	[ALE-02]	The number of axle settings In accumulative weighing mode, the number of axle should be pre-setted.
2	press  or  press  press 	[SN--23]	Cargo number setting
3	press  or  press  press 	[PF - 1]	Printing format setting 0: No printing 1:normal printing format for normal weighing. 2:Accumulative printing format for accumulative weighing.
4	press  or  press  press 	[PM - 1]	Printing method 0: manual 1:automatic
5	press  or  press 	[PC - 1]	Printing coupon numbers setting 1/2/3

	press 		
6	press  or  press 	[Baud-1]	Baud rating setting 0:600; 1:1200; 2:2400; 3:4800 4:9600; 5:19200; 6:38400 7:57600; 8:115200
7	press  or  press 	[CP - 1]	Communication format setting . 0: communication is off. 1: Communication format 1, connected to PC.
8	press or / or  press   	[OFF-00] [OFF-10]	Automatic power off setting: 00: no power-off Automatic power-off after ten min.
9	press or / or   press   	[BL--00] [BL--10]	Back lit setting 00:Back lit on 10:Back lit off after ten seconds. Backlist off: in zero condition and no operation.
10	press  or press 	[Date-0] [Date-2]	Date format. Format 0:year,month,day Format 1:month,day,year Format 2:day,month,year
11	 press or / or   press   	[30.07.13] [11.08.13]	Date setting: [11.08.13]
12	press or / or   press   	[14:13:20] [15:17:30]	Time setting: [15:17:30]

Step	Operation	Display	Remark
		[F 4]	F4 menu

1	press 	[S-0560]	560 records in indicator. Max. recording is 2000 cps.
2	press 	[HE-1.0A]	PCB version 1.0A
3	press 	[SE-1.00]	Software version 1.00
4	press 	[LFW code]	Check the left front wheel ad code
5	press 	[RFW code]	Check the right front wheel ad code
6	press 	[LRW code]	Check the left back wheel ad code
7	press 	[RRW code]	Check the right back wheel ad code

Step	Operation	Display	Remark
		[F 5]	F5 menu
1	press 	[dELA-0] [dEAL-1]	0:No deleting the weighing record. 1:Deleting the weighing record.
2	press  or  press 	[dEAL-0] [dEAL-1]	0:No deleting all the records. 1:deleting all the records.

F6 adds the function of restoring factory settings and equipment self-test

5.Serial interface reception command

5.1 Command 1

(RS232COM serial interface can receive simple ASCII command)

RS232 parameter:9600Bit/S Baud rate,8 digits,no check point,1 stop.

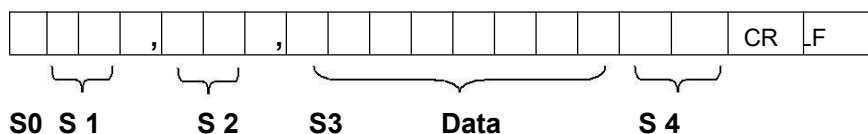

S1: weight status, ST= standstill, US= not standstill, OL= overload

S2: weight mode, GS= gross mode, NT= net mode

S3: weight of positive and negative, "+" or "-"

S4: "kg" or "lb"

Data: weight value, including decimal point

CR: carriage return

LF: line feed

5.2 Command 2

(workable with second display from Yaohua, Baud rate 600)

6.Print format

6.1 Normal Printing format

Single pad :	Double pads :	Three pads:	Four pads :
WEIGHING REPORT	WEIGHING REPORT	WEIGHING REPORT	WEIGHING REPORT
-----	-----	-----	-----
NO. : 0575	NO. : 0575	NO. : 0575	NO. : 0575
Date: 2013-11-02	Date: 2013-11-02	Date: 2013-11-02	Date: 2013-11-02
Time: 09:59:04	Time: 09:59:04	Time: 09:59:04	Time: 09:59:04
Vehicle:	Vehicle:	Vehicle:	Vehicle:
Cargo:34	Cargo:34	Cargo:34	Cargo:34
LFW: 429.0kg	LFW:429.0kg	FW: 429.0kg	LFW: 429.0kg
-----	RFW:413.5kg	LRW: 319.0kg	RFW: 413.5kg
Net: 429.0kg	Axle1:842.5kg	RRW: 293.0kg	Axle1: 842.5kg
Tare:0.0kg	-----	Axle2: 612.0kg	LRW: 319.0kg
Gross: 429.0kg	Net:842.5kg	-----	RRW: 293.0kg
Operator:	Tare:0.0kg	Net: 1041.0kg	Axle2: 612.0kg
	Gross: 842.5kg	Tare:0.0kg	-----
	Operator:	Gross: 1041.0kg	Net: 1454.5kg
		Operator:	Tare:0.0kg
			Gross: 1454.5kg
			Operator:

6.2 Accumulative printing format

Double pads (Double axles)

Four pads: (Four axles)

WEIGHING REPORT

WEIGHING REPORT

NO. : 0594

NO. : 0594

Date: 2013-11-02

Date: 2013-11-02

Time: 11:10:41
 Vehicle:
 Cargo:34
 LW: 420.5kg
 RW: 419.5kg
 Axle01: 840.0kg
 LW: 309.5kg
 RW: 297.0kg
 Axle02: 607.0kg

 Net: 1447.0kg
 Tare:0.0kg
 Gross: 1447.0kg
 Operater:

Time: 11:10:41
 Vehicle:
 Cargo:34
 LFW: 420.5kg
 RFW: 419.5kg
 Axle01: 840.0kg
 LRW: 309.5kg
 RRW: 297.0kg
 Axle02: 607.0kg
 LFW: 420.5kg
 RFW: 419.5kg
 Axle03: 840.0kg
 LRW: 309.5kg
 RRW: 297.0kg
 Axle04: 607.0kg

 Net: 2894.0kg
 Tare:0.0kg
 Gross: 2894.0kg
 Operater:

7.Maintenance

7.1 Regular error and solution

ERROR	REASON	SOLUTION
UUUUUU	1.Overload 2.wrong connection with load cell 3. load cell has quality problem.	1. reduce the weight 2. check load cell connection 3. inspection load cell. Check the input and output
nnnnnnn	1.calibration is no good 2. wrong connection 3. load cell has quality problem	1. check scale is resisted or not, foot is kept level or not. 2. check load cell connection. 3. checking load cell
ERR10	Zering, not on stable weighing condition.	Zering, on stable weighing condition
ERR11	Zero and tare at same time.	Back to G.W, then Zero
ERR12	Out of the zero range	Move the extra load
ERR15	Tare, no on stable	Tare after stable weighing

	weighing condition	
ERR16	Tare when no load	To load some, then tare
ERR17	Out of tare range	Decrease the tare weight
ERR25	The S/N number wrong when checking the weighing record	Assure the S/N number within the Number of records
ERR30	Printing format wrong at accumulative weighing mode	Printing format setting"2"
ERR31	Working mode wrong at accumulative weighing mode	Working mode setting"2/4"
ERR32	Weighing over the span Or display range or unstable or failure of zero at accumulative weighing mode.	Load properly at zeroing, then printing after data stable.
ERR33	Display Error, Printing with the indicator at accumulative weighing mode.	Print the total weight after accumulating the weight of axles.
ERR34	Printing error at normal Weighing mode.	Stable then printing
ERR35	Printing format wrong at normal weighing mode.	Setting"1"

7.2 Daily maintain

1. Protect the indicator from strong sunlight to prolong the using life.
2. Good connection between load cell and indicator. Far from away from strong electric field, magnetic field.
3. Power off the indicator when lightning.
4. Power off the indicator firstly before plug and unplug.

7.3 Packing list

Packing list

S/N	ITEM	NAME	UNIT	QTY	PACKING
1	Weighing indicator		PCS	1	
2	Plastic bag		PCS	1	
3	Accessories bag		PCS	1	
4	Adapter	China/DC8.4V	PCS	1	
		US/DC8.4V	PCS	1	
		UK/DC/8.4V	PCS	1	
		EU/DC8.4V	PCS	1	
		AU/DC8.4V	PCS	1	
		OTHERS	PCS	1	
5	USER MANUAL		PCS	1	
6	RS232	3-core aviation plug	PCS	1	
7	Serial port plug	DB9-9 core	PCS	1	
8	Certificate		PCS	1	
9	Packing list		PCS	1	