

OP-915-BC BENCH SCALE CART

FEATURES

- For use with OP-915-SS bench scales
- Stainless steel welded construction
- Ideal for use in the food or chemical industry
- Wheeled design for effortless smooth movement, easy portability and fast set up
- Locking rear casters allows for stability
- Adjustable cart legs can be raised or lowered to fit into assembly lines
- Rear handle for easy transporting
- Removable indicator stand
- Tilt-able indicator for eliminating glare
- 1,000 lb capacity

PART#	SIZE	SHIP WT.
OP-915-CT18	For 18" x 18" platforms	50 lbs
OP-915-CT24	For 24" x 24" platforms	70 lbs

* SHOWN WITH BENCH SCALE (SOLD SEPARATELY)

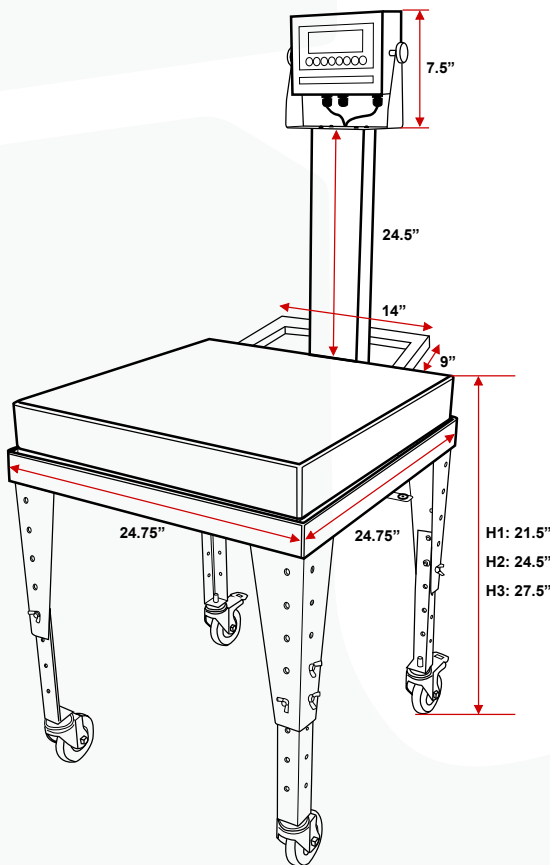

* SHOWN WITH 4 CASTERS (OPTIONAL)

